

Burford Research Consultants
 Burford House
 Cookham Dean
 Berks SL6 9AQ
 United Kingdom



01628-898616

1371

BRC No: 2849
Report Date: 27th October 2014

REPORT ON CRC TESTED IN ACCORDANCE WITH ISO 8317: 2004

| | |
|--|---|
| Name of Client | S.C. Johnson Europe BV |
| Address of Client | Groot Mijdrechtstraat 81 3641 RV Mijdrecht THE NETHERLANDS |
| Telephone Number | Tel: +31 297 292 355 |
| Specification Number | ISO 8317: 2004 |
| Description of Container Design submitted for Test | 1 litre HDPE bottle with 28mm Push Down and Turn PP/HDPE Deep Venting Clicloc Assembly containing EPE 30 Uni-Foam liner. |
| Drawing Numbers | Bottle: 4389 / 14 TE Cap: X945.00.00.se.customer Issue 8 |
| Tested empty or with solids or liquids | With water |
| Method of Testing (a) adult (b) children | 100 quota sequential testing |
| Dates of testing | 8 th – 24 th October 2014 |
| Name of Test Supervisor(s) | H D CAWTHORNE H Waddington |
| STATEMENT | I certify that this test was completed in accordance with ISO 8317: 2004 I certify that this container passed. Signed: <u></u> |

INDEX**Report 2849**

| | Page |
|--|--------------|
| Full test/product data | 1 |
| Containers rejected, damaged or broken | 2 |
| Manufacturer's instructions | |
| to BRC | 2 |
| for adult testers | 2 |
| Verbatim instructions from BRC | |
| to children | 2 |
| to adults | 2 |
| Summary of results | 3 |
| Child results | 4 - 8 |
| Adult results | 9 - 11 |
| Child graphs | Figure 1 & 2 |
| Manufacturer's drawings | |

Preliminary examination of containers

Number supplied: 350

The containers used for testing by both children and adults are opened and properly closed once by the Test Supervisor.

Containers which incorporate a tamper-evident seal in addition to a child resistant closure have the seal broken, are opened and properly reclosed by the Test Supervisor prior to being tested.

Box 1 below contains the number, if any, of containers rejected during the random selection of those to be tested. These containers are retained for possible examination by the Test Assessor.

Box 2 details containers broken or damaged during testing permitting leakage of contents.

| <u>Box 1</u> | <u>Box 2</u> |
|--------------|--------------|
| None | None |

Manufacturer's Instructions : to BRC for opening and closing
 To open: Push Down and Unscrew.
 To close: Close Tightly.

: for adult testers on lid of CRC
 Pictogram

Verbatim instructions given to children:

Pre first 5 minutes: Please try to open this for me
 Pre demonstration: Watch me open my package
 Pre second 5 minutes: Now you try to open your packages.

Verbatim instructions given to adults:

Pre-test Please open this package according to the instructions (if any).

After opening: Please will you reclose the container so that you are satisfied that it is child-resistant.

Summary of Results

Children

| | |
|----|---|
| 30 | children were tested |
| 30 | failed to open the CRC at all |
| 0 | successfully opened before demonstration |
| 0 | successfully opened after demonstration |
| 0 | successfully opened in total |
| 6 | sessions in nursery schools and playgroups were visited to provide the children tested on 8 th , 15 th , 20 th and 22 nd October 2014 |

Adults

| | |
|-----|---|
| 100 | adults were tested |
| 100 | successfully opened and re-closed the CRC |
| 0 | failed to open the CRC |
| 0 | failed to reclose the CRC satisfactorily |

Torque

Torque applied at 14 inch-pounds

Numbers of children in each sex and age group who carried out the test:

| | Age to nearest month | | | | | Totals |
|--------|----------------------|----------|----------|----------|----------|--------|
| | 42 43 | 44 45 | 46 47 | 48 49 | 50 51 | |
| Male | 4 | 3 | 3 | 3 | 2 | 15 |
| Female | 3 | 3 | 4 | 2 | 3 | 15 |
| Total | 7 | 6 | 7 | 5 | 5 | 30 |

Numbers of children in each sex and age group who opened the CRC:

| | Age to nearest month | | | | | Totals |
|--------|----------------------|----------|----------|----------|----------|--------|
| | 42 43 | 44 45 | 46 47 | 48 49 | 50 51 | |
| Male | 0 | 0 | 0 | 0 | 0 | 0 |
| Female | 0 | 0 | 0 | 0 | 0 | 0 |
| Total | 0 | 0 | 0 | 0 | 0 | 0 |

Numbers of children in each sex and age group who opened the CRC before demonstration:

| | Age to nearest month | | | | | Totals |
|--------|----------------------|----------|----------|----------|----------|--------|
| | 42 43 | 44 45 | 46 47 | 48 49 | 50 51 | |
| Male | 0 | 0 | 0 | 0 | 0 | 0 |
| Female | 0 | 0 | 0 | 0 | 0 | 0 |
| Total | 0 | 0 | 0 | 0 | 0 | 0 |

Numbers of children in each sex and age group who opened the CRC after demonstration:

| | Age to nearest month | | | | | Totals |
|--------|----------------------|----------|----------|----------|----------|--------|
| | 42 43 | 44 45 | 46 47 | 48 49 | 50 51 | |
| Male | 0 | 0 | 0 | 0 | 0 | 0 |
| Female | 0 | 0 | 0 | 0 | 0 | 0 |
| Total | 0 | 0 | 0 | 0 | 0 | 0 |

The children who took part were as follows:

| <u>Identity No.</u> | <u>Age</u> | <u>Sex</u> |
|---------------------|------------|------------|
| 1 | 46 | M |
| 2 | 44 | F |
| 3 | 42 | F |
| 4 | 43 | F |
| 5 | 42 | F |
| 6 | 43 | M |
| 7 | 43 | M |
| 8 | 42 | M |
| 9 | 48 | M |
| 10 | 48 | M |
| 11 | 49 | F |
| 12 | 46 | F |
| 13 | 48 | F |
| 14 | 48 | M |
| 15 | 46 | M |
| 16 | 46 | M |
| 17 | 50 | F |
| 18 | 50 | F |
| 19 | 44 | M |
| 20 | 44 | M |
| 21 | 44 | F |
| 22 | 50 | M |
| 23 | 44 | M |
| 24 | 50 | M |
| 25 | 46 | F |
| 26 | 43 | M |
| 27 | 44 | F |
| 28 | 50 | F |
| 29 | 47 | F |
| 30 | 46 | F |

For each of the children who were **able** to open the container **before** having received a demonstration, the child's identification number, sex and age and means of opening employed are listed below.

| Child Identification number | Sex | Age (months) | Means of opening employed |
|-----------------------------|-----|--------------|---------------------------|
| | | | |

For each of the children who were **able** to open the container **after** having received a demonstration, the child's identification number, sex and age and means of opening employed are listed below.

| Child Identification number | Sex | Age (months) | Means of opening employed |
|-----------------------------|-----|--------------|---------------------------|
| | | | |

Summary of characteristics of adults used in tests

Test date: 21st and 24th October 2014

Site of test: Wokingham, High Wycombe, Reading, Bracknell

The number of adults in each sex and age group who carried out the test (100 in total)

Age Group

| | 50 - 54 | 55 - 59 | 60 - 70 | Totals |
|--------|---------|---------|---------|--------|
| Male | 7 | 8 | 15 | 30 |
| Female | 18 | 17 | 35 | 70 |

Summary of results of tests with adults

Number of adults who were able to open and properly reclose the container: 100

Sex and age of those who successfully opened and reclosed the container

Age Group

| | 50 - 54 | 55 - 59 | 60 - 70 | Totals |
|--------|---------|---------|---------|--------|
| Male | 7 | 8 | 15 | 30 |
| Female | 18 | 17 | 35 | 70 |

The number of adults who were unable to open the container 0

The number of adults who failed to reclose the container properly 0

For each of the adults who were unable to open the container, the adult's identification number and reason for the adult concerned being unable to open the container are listed below.

| Adult Identification number | Sex | Age | Reason for being unable to open the container |
|-----------------------------|-----|-----|---|
| | | | |

For each of the adults who were able to open the container but unable to reclose it properly, the adult's identification number sex and age and reason for the adult concerned being unable to reclose the container are listed below.

| Adult Identification number | Sex | Age | Reason for being unable to reclose the container properly |
|-----------------------------|-----|-----|---|
| | | | |

| Adult ID No | Time Taken To Open In 5 Minute test | Time Taken to Open In 1 Minute Test |
|--------------------|--|--|
| | | |
| | | |
| 1 | 12s | 8s |
| 2 | 9s | 7s |
| 3 | 10s | 6s |
| 4 | 7s | 6s |
| 5 | 8s | 6s |
| 6 | 8s | 8s |
| 7 | 6s | 5s |
| 8 | 9s | 8s |
| 9 | 9s | 8s |
| 10 | 7s | 5s |
| 11 | 6s | 5s |
| 12 | 5s | 4s |
| 13 | 8s | 4s |
| 14 | 6s | 5s |
| 15 | 7s | 6s |
| 16 | 10s | 7s |
| 17 | 7s | 8s |
| 18 | 8s | 6s |
| 19 | 10s | 7s |
| 20 | 8s | 8s |
| 21 | 9s | 9s |
| 22 | 6s | 5s |
| 23 | 8s | 8s |
| 24 | 7s | 6s |
| 25 | 10s | 9s |
| 26 | 5s | 4s |
| 27 | 6s | 5s |
| 28 | 4s | 4s |
| 29 | 5s | 4s |
| 30 | 8s | 6s |
| 31 | 8s | 6s |
| 32 | 9s | 7s |
| 33 | 6s | 6s |
| 34 | 6s | 5s |
| 35 | 7s | 6s |
| 36 | 9s | 9s |
| 37 | 6s | 7s |
| 38 | 9s | 8s |
| 39 | 7s | 7s |
| 40 | 6s | 5s |
| 41 | 6s | 4s |
| 42 | 4s | 4s |
| 43 | 5s | 4s |
| 44 | 7s | 5s |
| 45 | 4s | 4s |
| 46 | 10s | 8s |
| 47 | 7s | 6s |
| 48 | 6s | 8s |
| 49 | 6s | 5s |
| 50 | 11s | 7s |
| | | |
| | | |

| Adult ID No | Time Taken To Open In 5 Minute test | Time Taken to Open In 1 Minute Test |
|--------------------|--|--|
| | | |
| | | |
| 51 | 9s | 9s |
| 52 | 8s | 9s |
| 53 | 6s | 6s |
| 54 | 7s | 6s |
| 55 | 8s | 8s |
| 56 | 7s | 6s |
| 57 | 5s | 5s |
| 58 | 5s | 4s |
| 59 | 8s | 6s |
| 60 | 7s | 7s |
| 61 | 6s | 6s |
| 62 | 8s | 7s |
| 63 | 5s | 4s |
| 64 | 8s | 6s |
| 65 | 5s | 5s |
| 66 | 9s | 9s |
| 67 | 8s | 7s |
| 68 | 10s | 8s |
| 69 | 8s | 8s |
| 70 | 9s | 8s |
| 71 | 5s | 5s |
| 72 | 6s | 5s |
| 73 | 8s | 5s |
| 74 | 4s | 4s |
| 75 | 6s | 5s |
| 76 | 7s | 5s |
| 77 | 6s | 6s |
| 78 | 9s | 8s |
| 79 | 10s | 8s |
| 80 | 6s | 7s |
| 81 | 9s | 9s |
| 82 | 8s | 7s |
| 83 | 5s | 5s |
| 84 | 9s | 8s |
| 85 | 8s | 7s |
| 86 | 9s | 7s |
| 87 | 6s | 4s |
| 88 | 5s | 6s |
| 89 | 5s | 4s |
| 90 | 7s | 5s |
| 91 | 8s | 6s |
| 92 | 9s | 7s |
| 93 | 6s | 7s |
| 94 | 6s | 5s |
| 95 | 10s | 6s |
| 96 | 6s | 4s |
| 97 | 4s | 5s |
| 98 | 4s | 4s |
| 99 | 7s | 5s |
| 100 | 6s | 4s |

Figure 1: Without Demonstration - 2849 - SC Johnson

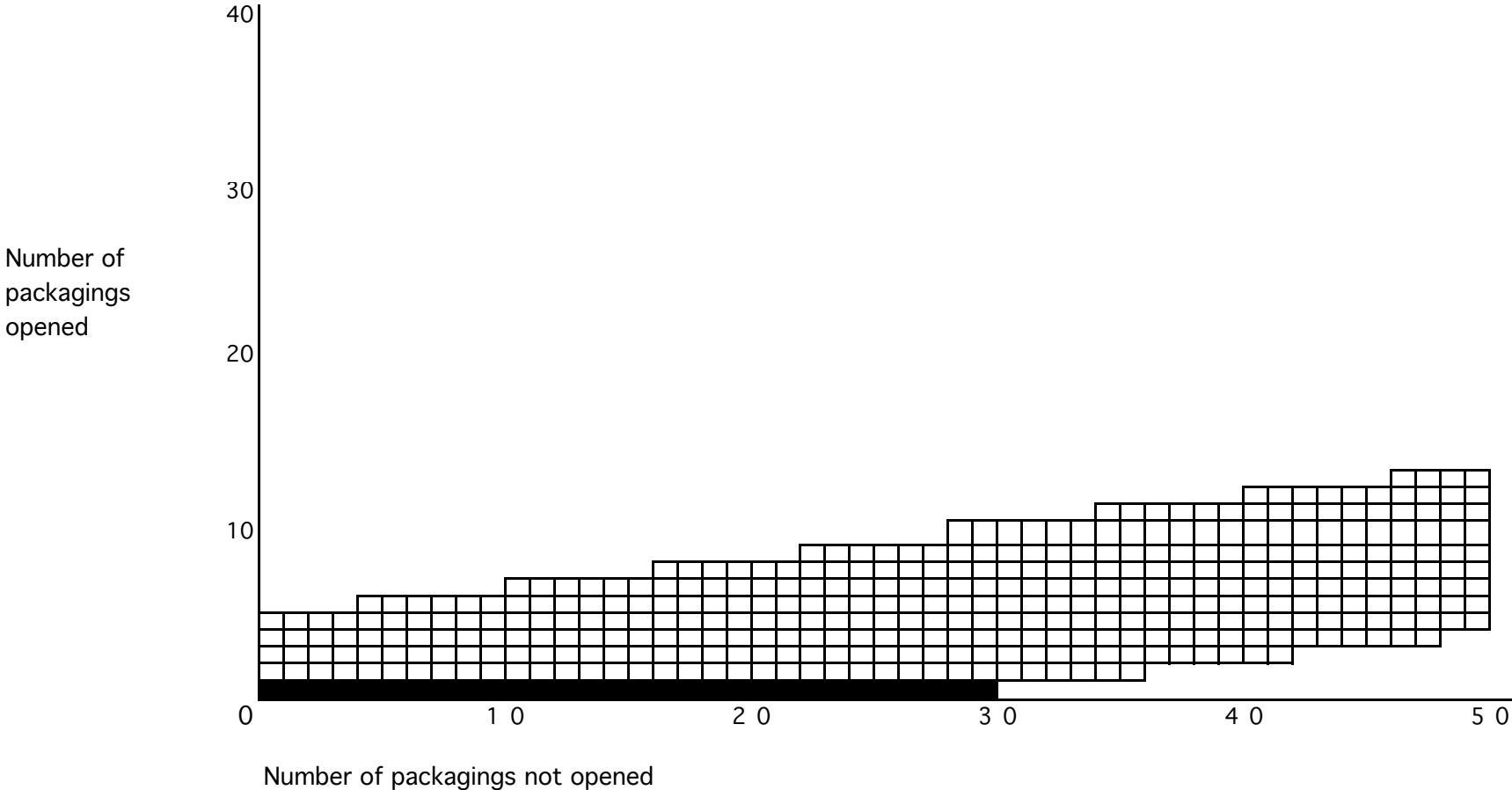
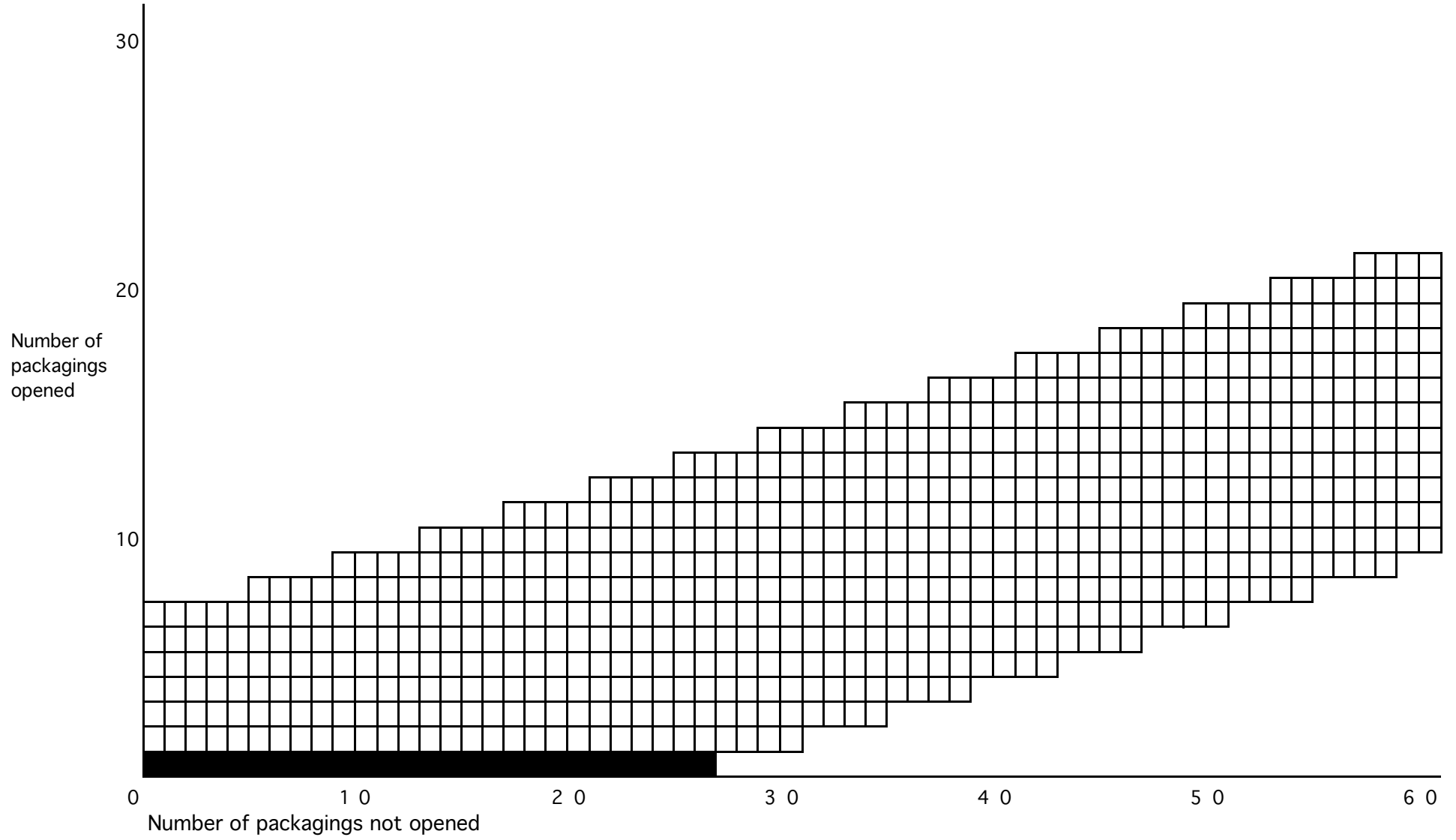
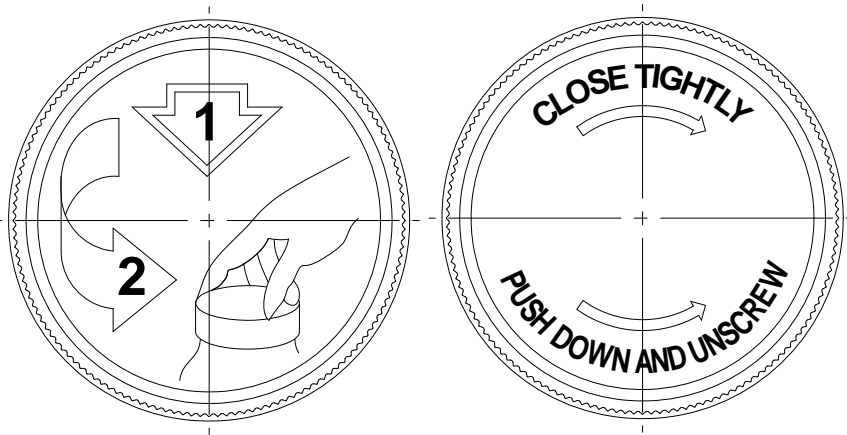

Figure 2: Before and After Demonstration - 2849 - SC Johnson



THIS IS A VISUAL REPRESENTATION SHOWING THE HANDS AND ARROW AND TEXT DESIGN



PLASTIC NECK FINISH

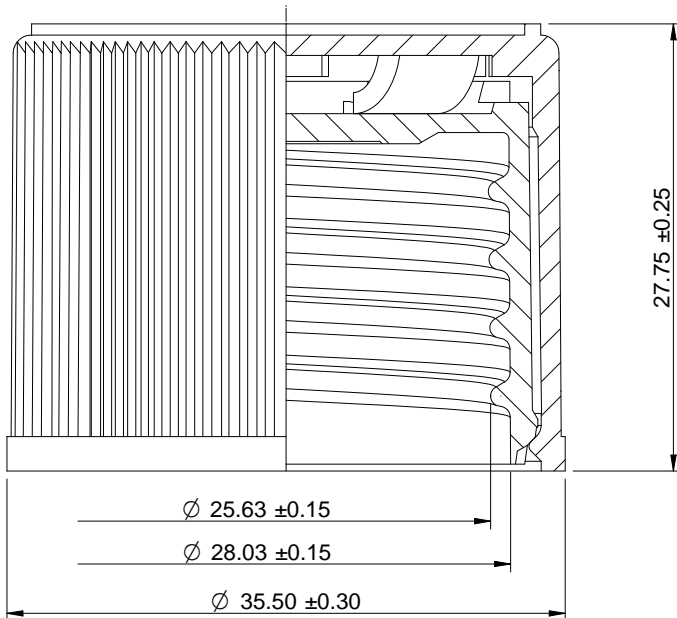
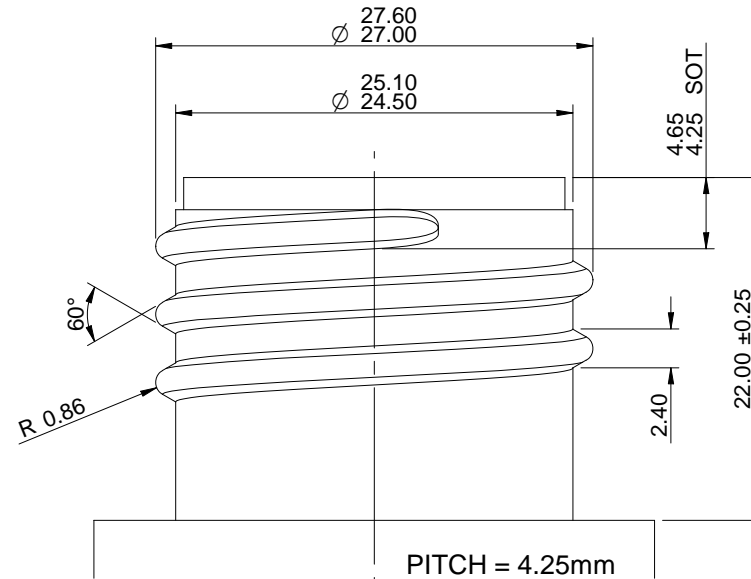

ASSEMBLY COMPRISES PARTS X822/X823

SHOULDER FORM TO BE DESIGNED TO RESIST NECK PUSH-DOWN WHEN REMOVING CLOSURE.
 WHERE POSSIBLE A MINIMUM BODY DIAMETER OF 35.00mm IS RECOMMENDED ON ALL CONTAINERS TO PROVIDE ANTI BITE-OFF PROTECTION.
 IT IS IMPORTANT THAT THE SEALING FACE OF THE NECK FACE SHOULD BE MAINTAINED AT 1.50mm MIN.

| | | | | | | | |
|-------|---|-----------|----------|---|--|------------------------|------------------------|
| 8 | COMMENTS UPDATED | DJM | 11/9/09 | THIS DRAWING AND THE DESIGN SHOWN HERE ON ARE THE EXCLUSIVE PROPERTY OF UCP PLC. THE DRAWING SHALL NOT BE COPIED OR THE CONTENTS COMMUNICATED OR REPRODUCED IN ANY FORM OR FOR ANY PURPOSE WITHOUT THE PRIOR SPECIFIC WRITTEN AUTHORITY OF UCP PLC. UCP PLC IS A CROWN CORK & SEAL COMPANY. | SUBJECT 28mm DEEPVENTING CLICLOC ASSEMBLY CUSTOMER GENERAL TRADE MATERIAL CO-POLYMER POLYPROPYLENE / HDPE | DRAWN | JCN |
| 7 | HANDS AND ARROWS PICTOGRAM ADDED | JDF | 26/4/07 | | | DATE | 16-9-93 |
| 6 | 27.75±0.25 WAS 27.92 ±0.25, 35.30±0.30 WAS 35.10±0.20 | MCB | 23/01/07 | | | THIRD ANGLE PROJECTION | |
| 5 | SPLINE DIMENSIONS REMOVED, NOTE ADDED | MCB | 23/3/05 | | | SCALE | 6:1 |
| 4 | 22.00 ±0.25 was 21.4 ±0.25 | DJM | 15-5-02 | | | DRAWING NUMBER | X945.00.00.se.customer |
| 3 | KNURL DIMENSIONS REMOVED | DJM | 20-3-02 | | | | |
| 2 | Redrawn on SOLID EDGE | MF | 20-8-01 | | | | |
| ISSUE | ALTERATION DETAILS | SIGNATURE | DATE | | | | |

X945



UNITED CLOSURES & PLASTICS PLC
 SALHOUSE ROAD, NORWICH, NR79AL
 TEL:01603423131 FAX:01603487285

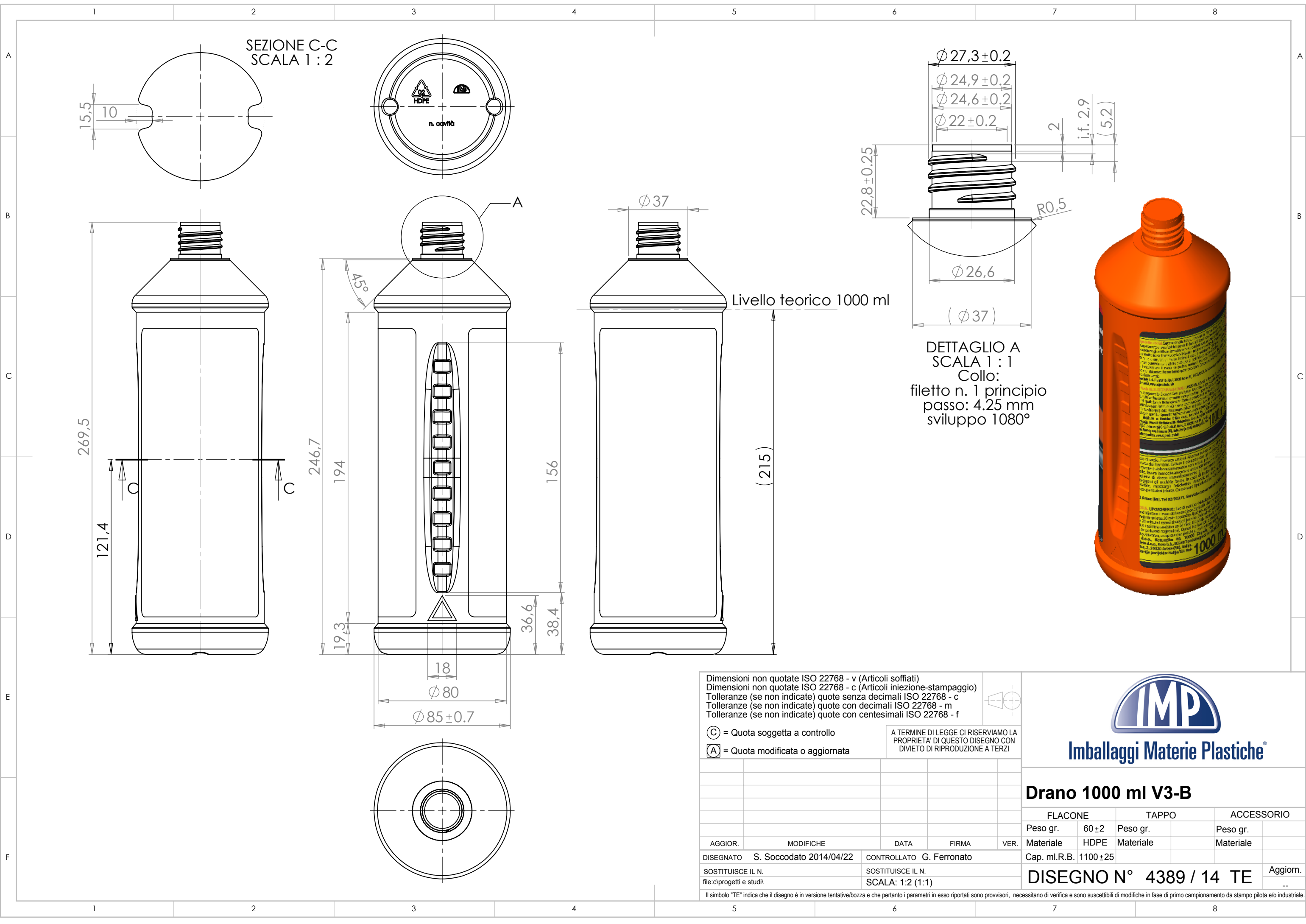

SEZIONE C-C
SCALA 1:2

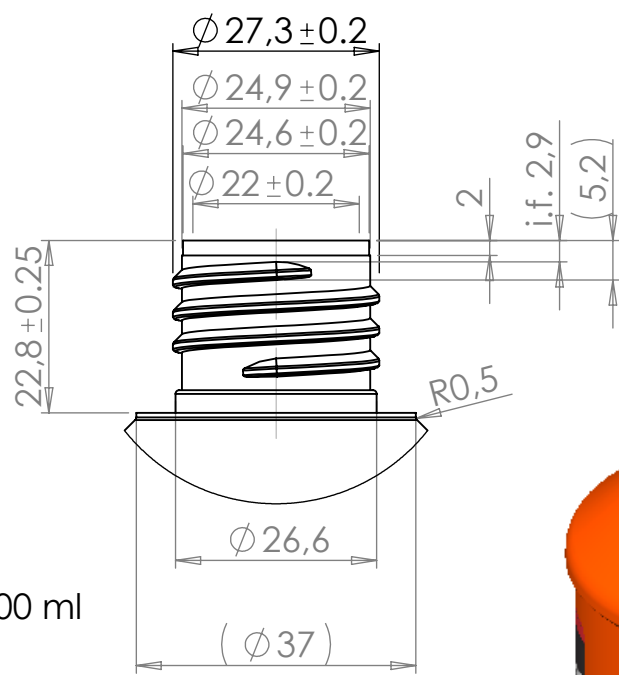

DETAGLIO A
 SCALA 1:1
 Collo:
 filetto n. 1 principio
 passo: 4.25 mm
 sviluppo 1080°



Livello teorico 1000 ml

Dimensioni non quotate ISO 22768 - v (Articoli soffiati)
 Dimensioni non quotate ISO 22768 - c (Articoli iniezione-stampaggio)
 Tolleranze (se non indicate) quote senza decimali ISO 22768 - c
 Tolleranze (se non indicate) quote con decimali ISO 22768 - m
 Tolleranze (se non indicate) quote con centesimali ISO 22768 - f

(C) = Quota soggetta a controllo
 (A) = Quota modificata o aggiornata

A TERMINE DI LEGGE CI RISERVAMO LA
 PROPRIETA' DI QUESTO DISEGNO CON
 DIVIETO DI RIPRODUZIONE A TERZI



Imballaggi Materie Plastiche®

Drano 1000 ml V3-B

| FLACONE | | TAPPO | | ACCESSORIO | |
|--------------|-----------|-----------|--|------------|--|
| Peso gr. | 60 ± 2 | Peso gr. | | Peso gr. | |
| Materiale | HDPE | Materiale | | Materiale | |
| Cap. ml.R.B. | 1100 ± 25 | | | | |

| AGGIOR. | MODIFICHE | DATA | FIRMA | VER. |
|---------|-----------|------|-------|------|
| | | | | |

DISEGNATO S. Soccodato 2014/04/22 CONTROLLATO G. Ferronato
 SOSTITUISCE IL N. SOSTITUISCE IL N.
 file:c:\progetti e studi\ SCALA: 1:2 (1:1)

DISEGNO N° 4389 / 14 TE

Aggiorn. --

Il simbolo "TE" indica che il disegno è in versione tentativi/bozza e che pertanto i parametri in esso riportati sono provvisori, necessitano di verifica e sono suscettibili di modifiche in fase di primo campionamento da stampo pilota e/o industriale.

| | |
|---------------------------|---|
| Closure Data Sheet | 28mm Vented Clic-Loc Black (X945) |
| JDE Number | N/A |
| Outer | <ul style="list-style-type: none"> • HDPE Rigidex HD5218EA • Exxon Mobil HMA016 • ESS-7940 Black M/B • Slip SL91695 |
| Inner | <ul style="list-style-type: none"> • PPH Sabic PP576S Nat |
| Liner | <ul style="list-style-type: none"> • 30mm x 2mm EPE 30 Uni-foam |
| Tamper Evident | <ul style="list-style-type: none"> • N/A |
| Ink | <ul style="list-style-type: none"> • N/A |
| Adhesive | <ul style="list-style-type: none"> • B640/67 Forbo Swift |
| Carton | <ul style="list-style-type: none"> • Size 389 x 285 x 303mm • 825 per carton |
| Pallet | <ul style="list-style-type: none"> • Pallet 1200 x 800 x 1140mm. |
| Pallet Qty | <ul style="list-style-type: none"> • 30 cartons x 825 (24,750) |